

FORMOST®

THE FORMOST COMBINATION BAGGER

Quality is "First and Formost"



GT-5

**Combination
Bread & Roll Bagger**

POSITIVE PRODUCT CONTROL

MAINTAINS PRODUCT QUALITY

GENTLE PRODUCT HANDLING

QUICK, SIMPLE CHANGEOVER

UP TO 75 BAGS PER MINUTE

GT OR JV-60 MODELS

GENTLE , DEPENDABLE BAGGING

The Formost Combination Bagger provides the kind of versatility that really pays off. Its ideal for single oven operations and variety plants like those specializing in Italian or French style bakery products. The Combination Bagger bags sliced bread faster and more gently than machines designed to handle bread alone. Then it works on everything else in the bakery - loose rolls, brown 'n serve rolls, cluster buns, hearth-baked bread, donut trays, sweet rolls, English muffins... you name it. The Combination Bagger pays its way as a bread bagger - all the rest is a bonus.

Formost Packaging Machines, Inc.

19211 144th Avenue NE • Woodinville, WA 98072

Phone: 425-483-9090 • Fax: 425-486-5656 • email: sales_dept@formostpkg.com

www.formostpkg.com

Reliable Bread & Roll Bagging

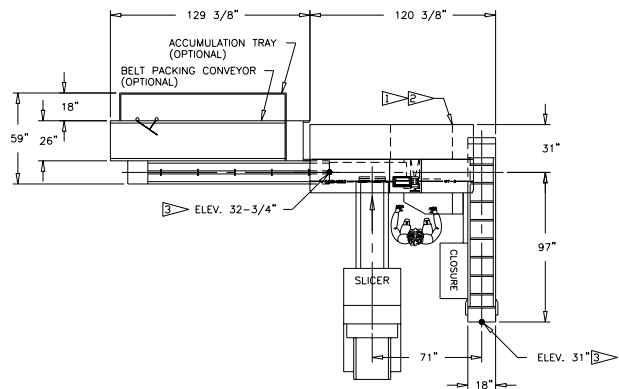
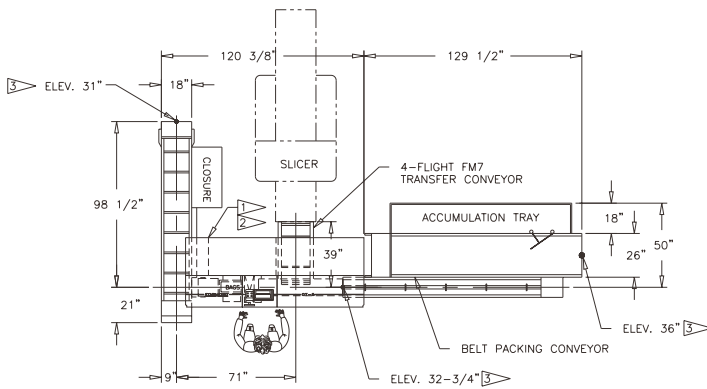

The Formost Combination Bagger is available in several left and right hand configurations.



The Combination Bagger is equipped with separate infeeds for sliced bread and other bakery products. Changeover is quick and easy.



The specially designed paddles gently push the product through the openers and into the bag, creating a tight bag for best appearance.

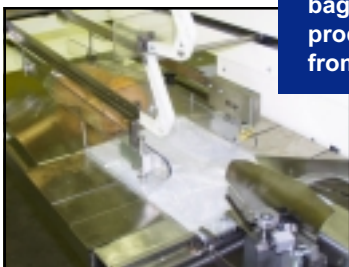

After the product is placed in the bag, the bag openers release and product motion separates the bag from the wicket.

Optional Features

- Automatic bag closure device
- Wide product capability
- Spare Parts Kit
- Rear infeed configuration
- In-line infeed configuration
- Continuous or multi-wicket bag feed
- Rotary bag feed available on GT Models

FORMOST COMBINATION BAGGER SPECIFICATIONS

	ALL MODELS MIN. DIMENSIONS	STANDARD MODEL MAX. DIMENSIONS	WIDE MODEL MAX. DIMENSIONS
PRODUCT LENGTH	6" (152 mm)	16" or 24" (406/610 mm)	16" (406 mm)
PRODUCT WIDTH	3" (76 mm)	8.5" (216 mm)	11.5" (292 mm)
PRODUCT HEIGHT	2" (51 mm)*	5.5" (140 mm)	5.5" (140 mm)
BAG LENGTH	10" (254 mm)	20" (508 mm)	20" (508 mm)
BAG WIDTH	5" (127 mm)	12" (305 mm)	15" (381 mm)

*Note: For products less than 2 inches high, machine equipped with horizontal opener action should be used. These specifications may vary according to special applications. Specifications are based upon the latest information available at the time of publication. Formost reserves the right to make changes in materials, equipment and specifications without prior notice.