

PREMIUM BREAD BAGGING SYSTEM

Quality is "First and Formost"

GTS Bagger



DOUBLE BAGGED FOR OPTIMAL FRESHNESS

EASY OPEN INNER BAG

SERVO OVERHEAD OPTION

REDUCE BOTTLENECKS

PROVEN TECHNOLOGY

INCREASED THROUGHPUT

QUICK, EASY CHANGEOVER



Formost Fuji developed an innovative and attractive package for premium breads that are presently wrapped and bagged. Instead of being wrapped, the loaf is bagged and sealed, creating a tight, tamper evident, easily opened inner package. The tightly packaged loaf is then placed in an outer bag.

The perforated inner bag is easily opened to enable the removal of slices, while maintaining package integrity and appearance.

FORMOST FUJI CORPORATION

19211 144th Avenue NE • Woodinville, WA 98072

Phone: 425-483-9090 • Fax: 425-486-5656 • email: salesoffice@formostfuji.com

www.formostfuji.com

FORMOST

FUJI

Premium Bread Packaging

Patent Pending

The Formost Fuji Premium Bread Double Bagging System is available in several configurations. Contact Formost for system specifications.

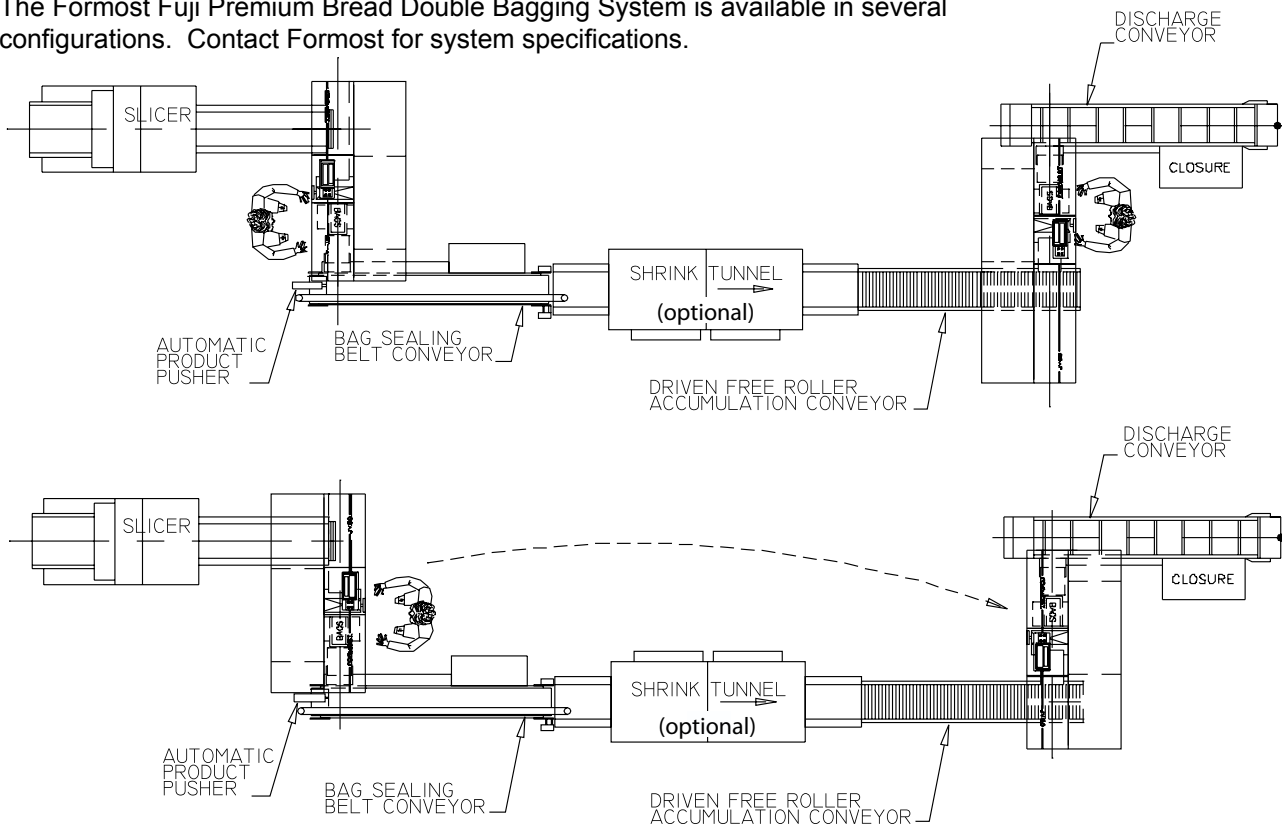

The inner bag is sealed creating a tight, attractive and tamper evident package. The bag can be run through a shrink tunnel for an even tighter package.



The bag is perforated for easy opening and removal of slices. Package integrity is maintained.

Optional Features

Closure Style Changeover

Swap the heat sealer for a closure unit to run sandwich breads.

Wide Product Capability

Allows double loaf packaging of warehouse club packs.

Shrink Tunnel

For that completely tight look or consistent appearance for bread that varies in size.

FORMOST FUJI CORPORATION

19211 144th Avenue NE • Woodinville, WA 98072

Phone: 425-483-9090 • Fax: 425-486-5656 • email: salesoffice@formostfuji.com

www.formostfuji.com

